



Angle of rotation tester

SmartCheck Angle

Product no. **96521400**
GTIN **4018754323005**
Model **SmartCheck ANGLE**

Label.

Angle of rotation tester

Properties.

- for checking the angle of rotation measurement of angle-controlled torque wrenches for compliance with the specified tolerances
- angle of rotation measurements up to 720° with setpoint specifications
- immediate evaluation of the measurement results directly on the device using the traffic light principle
- with interchangeable square drive adaptors (1/4"- 3/8"-1/2")
- for angle-controlled torque wrenches with a measuring range of up to 400 Nm
- large LCD for optimum readability
- the display, the display holder, and the base can be rotated 180°
- the display and keypad are splash-proof, the case is made of impact-resistant plastic
- simple installation thanks to pre-drilled holes in the mounting bracket
- the rotating arm can be easily locked in the zero position for transport
- for controlled clockwise and counter-clockwise torque testing
- 2 operating modes: running display of the applied torque (Track), peak value display (Peak-Hold)
- customised input of target torques and tolerances for evaluating the measured value
- micro USB interface for data export and for power supply (if required)
- data storage for up to 2,500 data records, including date and time stamp
- CheckMaster documentation software for transferring values and creating test certificates is available free of charge at www.stahlwille.com
- operation via included power supply, batteries or rechargeable batteries (4 x AAA or 1 x 9 V block, adaptor included)
- with factory certificate
- in a sturdy plastic box
- delivered with USB power supply and square drive adaptors 1/4" and 3/8"

Benefits.

Electronic testing device for checking angle of rotation with immediate evaluation of the measurement results.

For angle of rotation measurements up to 720°. Includes an extendable rotating arm for testing in large measurement ranges.

The large LCD can be rotated 180° and is easy to read from any position.

Simple, quick and reliable testing of angle-controlled torque wrenches to ensure quality in production.

A simple adjustment of the supports enables quick adaptation to different handle lengths and shapes.



Product highlights.



PRODUCT IMAGE
IN PROGRESS

Error-resistant angle of rotation test.

Our SmartCheck Angle is the first testing device of its kind to verify, check and document the angle of rotation. It measures angles of rotation of up to 720° and features a target value specification as well as an evaluation of the results using the practical traffic light principle. The digital measurement not only enables the continuous display of the angle of rotation, but also the recording of the peak value. With its outstanding precision, it can easily fulfil the most demanding industrial requirements.



PRODUCT IMAGE
IN PROGRESS

Optimum viewing angle.

The compact tester can be adjusted to the optimal viewing angle. The display is visible from virtually anywhere, as not only the large LCD, but also the display holder and the base can be rotated through 180°.



PRODUCT IMAGE
IN PROGRESS

Communication and power supply via USB.

The SmartCheck is equipped with a practical micro USB interface that allows the stored test values to be read out and simplifies their transfer to external systems. The USB port can also be used as an optional power supply for the device.



**PRODUCT IMAGE
IN PROGRESS**

Comprehensive documentation.

The SmartCheck testing device can be easily configured with the CheckMaster software allowing direct evaluation of the measurement results. In this way, all data can be read out and saved on the PC for better monitoring and optimisation of work processes.



**PRODUCT IMAGE
IN PROGRESS**

Extended measuring range.

Our SmartCheck Angle is supplied with a short and long rotating arm (angle arm). This makes it easy to adapt to the handle length and geometry of different wrenches so that angle controlled torque wrenches with a larger measuring range can also be easily tested.

Technologies and features.



DIN EN ISO 6789-2

Our torque wrenches and torque screwdrivers are professionally calibrated in accordance with DIN EN ISO 6789-2 and delivered with a corresponding calibration certificate. We also calibrate angle-controlled torque wrenches in accordance with VDI 2648-2. This ensures the accuracy and traceability of our tools.

Technical drawing.

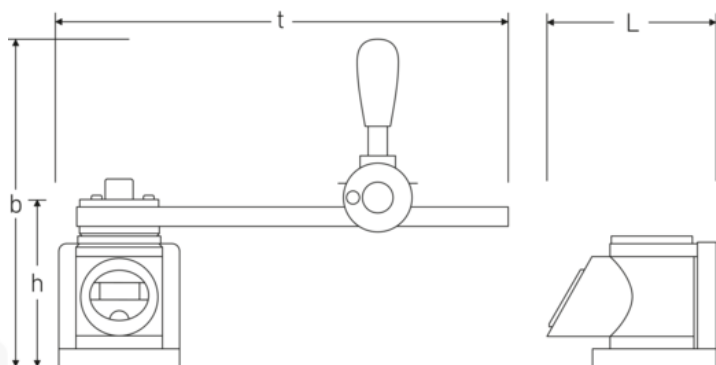

Technical attributes.

Measuring range N·m	-400 N·m
Length mm (L)	263 mm
Width mm (b)	452 mm

Logistics data.

Product no.	96521400
GTIN	4018754323005
Weight (g)	7800 g

Height mm (h)	326 mm	Volume (packaged, dm3)	58.30875 dm3
t	171 mm	Packing standard	1
		WEEE/ElektroG	Kleingeräte B2C
		Customs tariff no.	90318080
		Country of origin AWR	GERMANY
		Region of origin	Nordrhein-Westfalen
		Depth mm (IFS)	730
		Width mm (IFS)	375
		Height mm (IFS)	213
		Weight (gross, kg)	11,500
		Weight PAP (kg)	1,000
		Weight PVC (kg)	0,000
		Length (packaged, mm)	730
		Width (packaged, mm)	375
		Height (packaging, mm)	213

Parts list.



51110057
USB cable



52110063
USB power supply

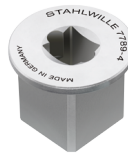

58524090
Square drive adaptor

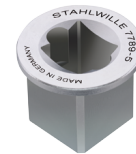

58524091
Square drive adaptor



81500004
Plastic box, empty

GTIN.



4 018754 323005



STAHLWILLE Eduard Wille GmbH

Lindenallee 27 · 42349 Wuppertal · Germany · Phone: +49 202 4791-0

info@stahlwille.de · www.stahlwille.com

© STAHLWILLE Eduard Wille GmbH, Wuppertal