

## Torque wrenches Service MANOSKOP® (N·m)

### 730 Quick



Product no.	50184002
GTIN	4018754292653
Model	730/2 QUICK



**Label.** MANOSKOP® torque wrench 730 Quick 4-20N·m 9 x 12 mm L. 179mm

- Properties.**
- clicking type with dual stop signal
  - no reset to "0" required
  - the measuring element is only under load when a force is applied.
  - mount for interchangeable insert tools
  - with QuickRelease safety lock
  - non-slip adjuster with thumb recess for quick torque adjustment
  - fine, tapered pointers
  - counter-clockwise tightening by turning the insert tool over
  - clicking mechanism insensitive to continuous loads and counter-loads (up to the max. measurement range of the torque wrench)
  - optimal calibration with perfectControl® calibration systems No. 7794 or calibration systems No. 7706, 7791
  - easy adjustment without disassembly via 2 external adjustment screws
  - with 2-component handle
  - calibration certificate in accordance with DIN EN ISO 6789-2:2017
  - **accuracy ± 4%**

## Product highlights.



### Rapid adjustment.

Easy and quick adjustment of the torque is carried out by an easy-to-operate clamping lever in the handle. The scale can be moved quickly and safely with an ergonomically shaped, non-slip adjustment element with thumb recess.



PRODUCT IMAGE  
IN PROGRESS

### Adjustment does not require disassembly.

Quick adjustment from outside, no disassembly of the torque wrench required, with 2 adjustment points for the maximum & minimum values.

## Technologies and features.

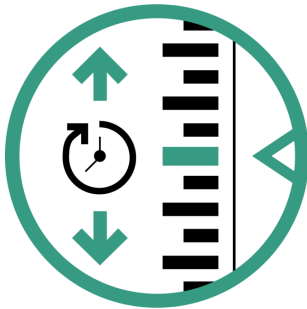

### QuickSelect

Lightning-fast target value setting: Unlock the adjustment knob, set the value, and lock the knob again.

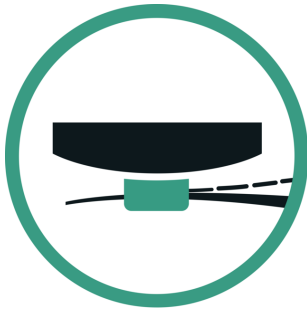

### Low-wear bending beam system

Our torque wrench is equipped with a low-wear release system with a bending beam. Unlike conventional torque wrenches with coiled springs, the bending beam is not subjected to any load until the tool is in operation, which means that resetting to '0' is not necessary after use.



### 2-component handle

Our 2-component handle is non-slip and ergonomically designed. It is resistant to the most common oils, greases, fuels, brake fluids, and Skydrol. The arrow markings on the handle indicate the direction of operation.



### DIN EN ISO 6789-2

Our torque wrenches and torque screwdrivers are professionally calibrated in accordance with DIN EN ISO 6789-2 and delivered with a corresponding calibration certificate. We also calibrate angle-controlled torque wrenches in accordance with VDI 2648-2. This ensures the accuracy and traceability of our tools.

## Technical drawing.

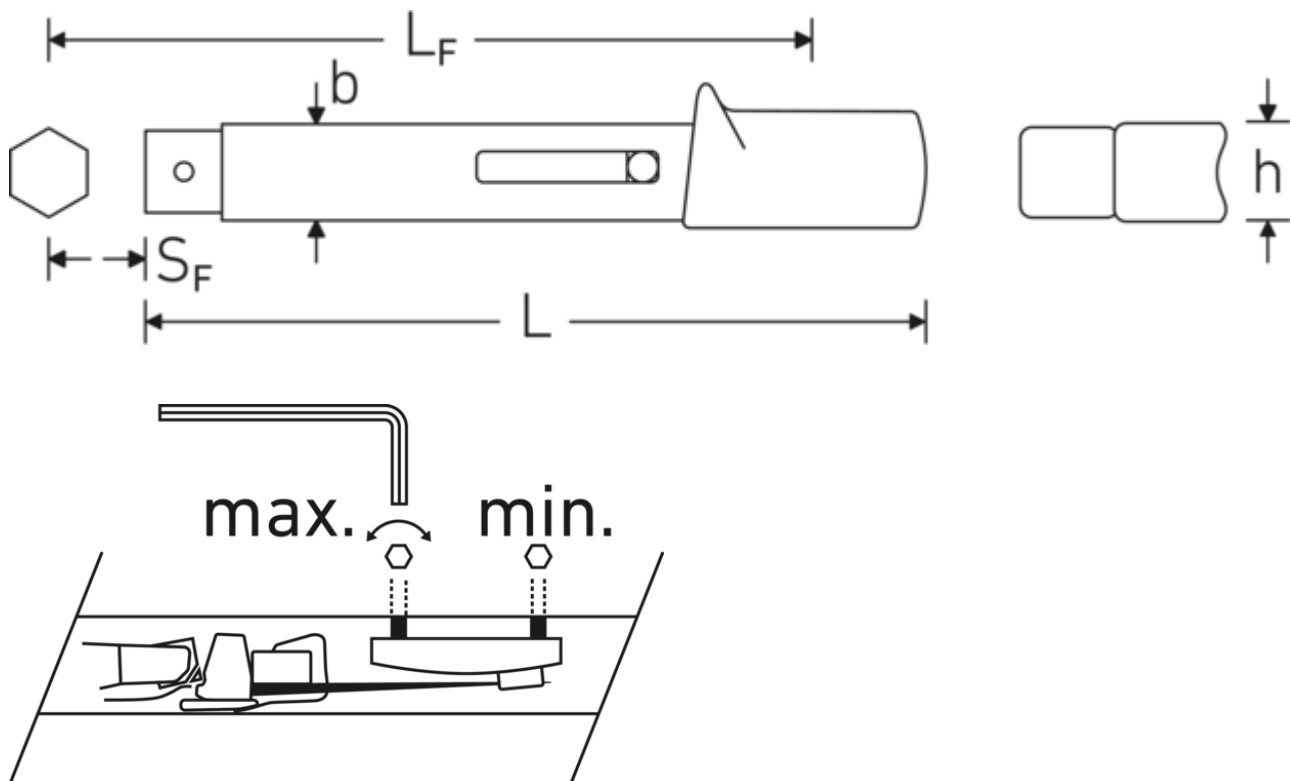

## Technical attributes.

Size	2
Anzeigeabweichung	± 4 %
Tool holder size [internal square]	9 x 12 mm
Measuring range N·m	4-20 N·m
Scale division N·m	0,5 N·m
Length mm (L)	179 mm
Width mm (b)	27,5 mm
Height mm (h)	23,6 mm
LF	157,2 mm
SF	17,5 mm

## Logistics data.

Product no.	50184002
GTIN	4018754292653
Weight (g)	315 g
Volume (packaged, dm <sup>3</sup> )	0.75625 dm <sup>3</sup>
Packing standard	1
WEEE/ElektroG	nicht ear-pflichtig
Customs tariff no.	82041100
Country of origin AWR	GERMANY
Region of origin	Nordrhein-Westfalen
Depth mm (IFS)	250
Width mm (IFS)	55
Height mm (IFS)	55
Weight (gross, kg)	0,390
Weight PAP (kg)	0,000
Weight PVC (kg)	0,062
Length (packaged, mm)	250
Width (packaged, mm)	55
Height (packaging, mm)	55

**GTIN.**



**STAHLWILLE Eduard Wille GmbH**

Lindenallee 27 · 42349 Wuppertal · Germany · Phone: +49 202 4791-0

[info@stahlwille.de](mailto:info@stahlwille.de) · [www.stahlwille.com](http://www.stahlwille.com)

© STAHLWILLE Eduard Wille GmbH, Wuppertal