

## Mobile workbench WB 621

### WB 621



Product no.	85010621
GTIN	4018754336241
Model	WB 621



#### Label.

Mobile workbench WB 621 7 Drawer anthracite, RAL 7016; black, RAL 9005  
L.500mm x W.1150mm x H.1045mm

#### Properties.

- three-stage safety concept:
  - central locking with a lateral cylinder lock and hinged key
  - individual locks prevent inadvertent opening during transit
  - tilt protection - makes it impossible to pull out several drawers at the same time
- 7 easily removable drawers, black, full-extension runners with bearing cage guide
- 2 drawers in generous XXL format, 880 mm
- separate lockable cabinet compartment with magnetic bracket and adjustable shelves (70 mm grid)
- drawers and cabinet compartment close at the same time
- large work surface with multiplex beechwood worktop (with FSC certification), 1,150 x 500 x 30 mm
- cabling through 2 rubber cable grommets
- removable cable duct on the back side
- oil and acid-resistant wheels (Ø 125 mm) with bearings protected from the ingress of dirt and fibres, and 2 parking brakes
- paper roll holder
- RAL 7016 body, RAL 9005 drawers and cabinet compartment, in durable industrial powder coating
- stainless steel decorative trim
- two-sided perforated panel for hooks (No. 8031-8041)
- available separately: e-kit consisting of a magnetic multi-plug with 2 USB ports, a magnetic holder (flexible positioning on any metallic part of the workbench), and a cable holder
- can be equipped with STAHLWILLE TCS inlays

#### Benefits.

Solid birchwood multiplex worktop with a working height of 104 cm.

With 7 full-extension drawers, 2 in XXL format, and a lockable cabinet section.

Three-stage safety concept with single lock and foldable key.

With cable outlets and a cable duct for an organised and safe working environment.

Can be extended with an e-kit with triple socket, cable and magnetic holder and USB ports.



## Product highlights.



### Perfectly equipped.

Our workbench is of course also available directly with matching tool sets. However, we are also happy to put together sets according to customer requirements for individual requirements. Just talk to us.



### Ergonomic height.

The working height of 104 cm and the particularly large, FSC-certified worktop makes work more comfortable.



### Reliable construction.

High-quality materials ensure the durability one expects from STAHLWILLE, such as the robust body and drawers with industrial powder coating. The oil and acid-resistant smooth-running wheels (Ø 125 mm) are equipped with guards to protect the bearings from dirt and fibres, and with 2 locking brakes.



### Secure down to the last detail.

The central lock with countersunk, side-mounted cylinder lock, together with the foldable key, protects against injury and damage. The individual locking mechanism prevents unintentional opening during transit - the anti-tilt protection makes it impossible to pull out multiple drawers simultaneously.



PRODUCT IMAGE  
IN PROGRESS

### Maximum storage space.

Our workbench offers generous storage space with 2 full-length XXL drawers, 5 large drawers and a lockable cabinet section. The WB 621 can be ideally organised with STAHLWILLE foam inlays: TCS inlays 3/3 (XL) for drawers 3-7 and a combination of one TCS inlay 3/3 and one TCS inlay 2/3 (L) for the 2 upper drawers.



PRODUCT IMAGE  
IN PROGRESS

### Smart cable management.

A detachable cable duct helps to neatly route and organise cables for electrical devices. This reduces the risk of tripping over or damaging the cable, thus increasing safety in the workplace. 2 cable outlets on the back also facilitate the power supply, e.g., when charging stowed battery-powered devices.

## Technologies and features.

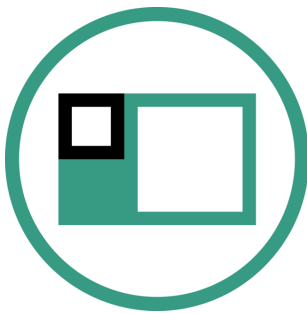

### Modular Inlay System

This flexible solution for tool storage makes it possible to customise your tool trolleys and workbenches with 1/6, 1/3, 2/3 or 3/3 foam inlays.

## Technical drawing.

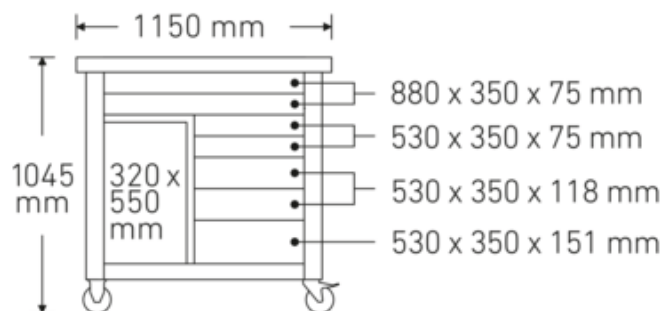
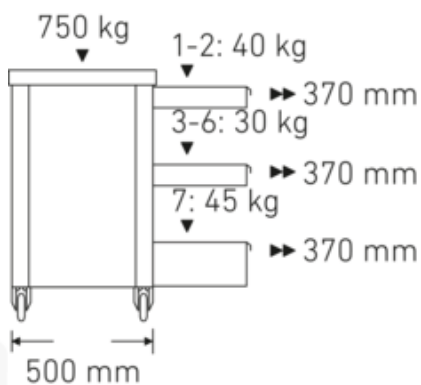

## Technical attributes.

Length mm (L)	500 mm
Width mm (b)	1150 mm
Height mm (h)	1045 mm

## Logistics data.

Product no.	85010621
GTIN	4018754336241
Weight (g)	97500 g

<b>Number of drawers</b>	7	<b>Volume (packaged, dm3)</b>	593.34 dm3
<b>Load capacity</b>	750 kg	<b>Packing standard</b>	1
<b>Internal drawer dimensions mm</b>	880 x 350 x 75 (2x) 530 x 350 x 75 (2x) 530 x 350 x 118 (2x) 530 x 350 x 151 (1x)	<b>WEEE/ElektroG</b>	nicht ear-pflichtig
<b>Drawer load capacity</b>	40 kg 30 kg 30 kg 45 kg	<b>Customs tariff no.</b>	94032080
<b>Colour</b>	anthracite, RAL 7016; black, RAL 9005	<b>Country of origin AWR</b>	CHINA
		<b>Region of origin</b>	Ausländischer Ursprung
		<b>Packaging</b>	in cardboard box/on pallet
		<b>Depth mm (IFS)</b>	1150
		<b>Width mm (IFS)</b>	500
		<b>Height mm (IFS)</b>	890
		<b>Weight (gross, kg)</b>	115,000
		<b>Weight PAP (kg)</b>	7,500
		<b>Weight PVC (kg)</b>	0,000
		<b>Length (packaged, mm)</b>	1160
		<b>Width (packaged, mm)</b>	550
		<b>Height (packaging, mm)</b>	930

## GTIN.



## Accessories (for).



80310090  
Single hook



90432727  
Spray can holder



80320060  
Twin hook

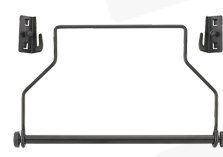

81483004  
Paper roll holder



80340040  
Twin hook



89010040  
Cable holder



80340050  
Twin hook



83812070  
Empty tray for small components



80350017  
Rectangular lug



80350020  
Rectangular lug



81484001  
Drawer divider



80360012  
Spring clip



81484002  
Drawer divider



80360018  
Spring clip



81485006  
Spring clip



80360024  
Spring clip



90432728  
Electronic kit



81485012  
Spring clip



80380030  
Container



80310030  
Single hook



80310060  
Single hook

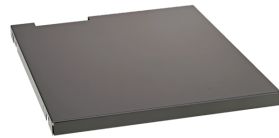

90432736  
Shelf



89010041  
Laptop holder



80320030  
Twin hook

## Spare part(s), spare part(s) for.



90432731  
Multiplex beechwood  
worktop



81490001  
Wheel set



89480003  
Wheel set



81490005  
Wheel set

# Images.





**STAHLWILLE Eduard Wille GmbH**

Lindenallee 27 · 42349 Wuppertal · Germany · Phone: +49 202 4791-0

[info@stahlwille.de](mailto:info@stahlwille.de) · [www.stahlwille.com](http://www.stahlwille.com)

© STAHLWILLE Eduard Wille GmbH, Wuppertal