

## Torque wrenches Service MANOSKOP® with fine-tooth ratchet

### 730NR



Product no. **96502140**  
GTIN **4018754180523**  
Model **730NR/40 FK**



#### Label.

Torque wrenches Service MANOSKOP® 730NR 60-300ft·lb 3/4 L. 657mm

#### Properties.

- clicking type with dual stop signal
- no reset to '0' required
- the measuring element is only under load when a force is applied
- with permanently installed fine-tooth ratchet
- fast, precise adjustment with QuickSelect quick adjustment
- dual scale N·m/ft·lb
- clicking mechanism insensitive to continuous loads and counter-loads (up to the max. measurement range of the torque wrench)
- optimal calibration with perfectControl® calibration systems No. 7794 or calibration systems No. 7706, 7791
- easy adjustment without disassembly via 2 external adjustment screws
- in sturdy plastic box (size 65 in sheet steel box)
- with 2-component handle
- calibration certificate in accordance with DIN EN ISO 6789-2:2017
- **accuracy ± 4%**

#### Product highlights.



PRODUCT IMAGE  
IN PROGRESS

##### **Adjustment does not require disassembly.**

Quick adjustment from outside, no disassembly of the torque wrench required, with 2 adjustment points for the maximum & minimum values.



### Reliable handling.

The haptic feedback and a clearly audible 'click' as a dual stop signal from the mechanical trigger reliably indicate that the target value has been reached.

## Technologies and features.

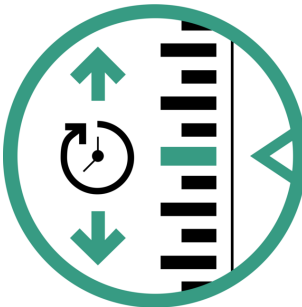

### QuickSelect

Lightning-fast target value setting: Unlock the adjustment knob, set the value, and lock the knob again.



### Low-wear bending beam system

Our torque wrench is equipped with a low-wear release system with a bending beam. Unlike conventional torque wrenches with coiled springs, the bending beam is not subjected to any load until the tool is in operation, which means that resetting to '0' is not necessary after use.



### 2-component handle

Our 2-component handle is non-slip and ergonomically designed. It is resistant to the most common oils, greases, fuels, brake fluids, and Skydrol. The arrow markings on the handle indicate the direction of operation.



### DIN EN ISO 6789-2

Our torque wrenches and torque screwdrivers are professionally calibrated in accordance with DIN EN ISO 6789-2 and delivered with a corresponding calibration certificate. We also calibrate angle-controlled torque wrenches in accordance with VDI 2648-2. This ensures the accuracy and traceability of our tools.

## Technical drawing.

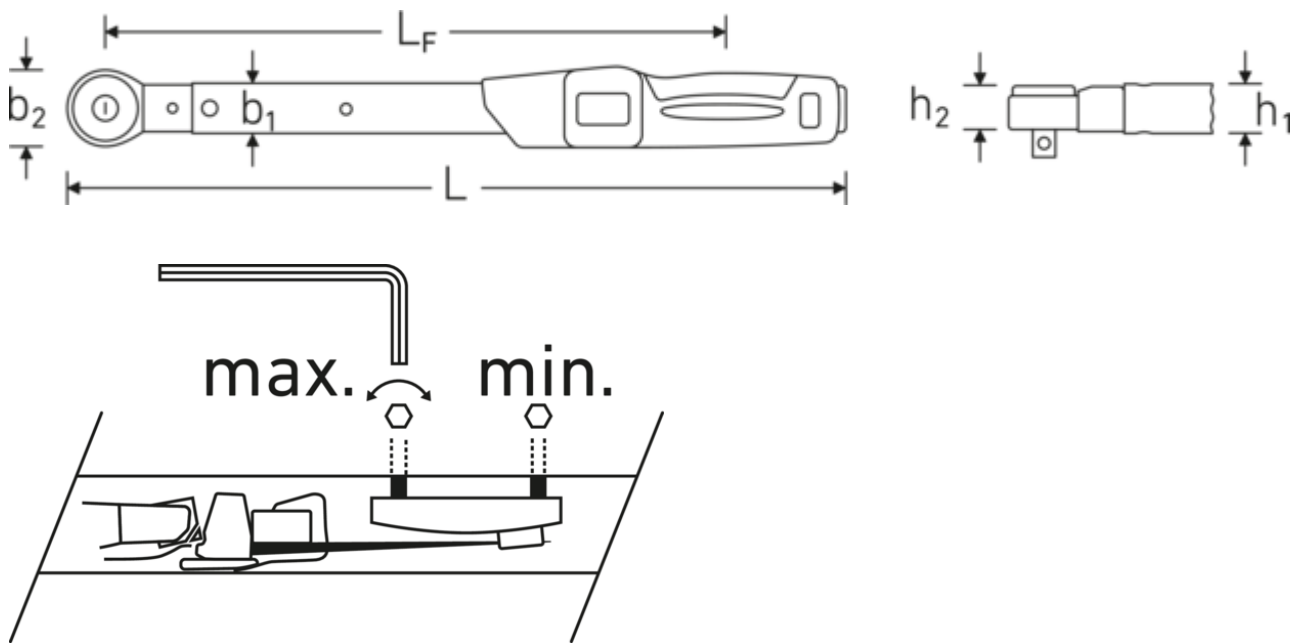

## Technical attributes.

Size	40 FK
Measuring range N·m	80-400 N·m
Measuring range ft·lb	60-300 ft·lb
Scale division N·m	20 N·m
Scale division ft·lb	10 ft·lb
Fine scale division	2 N·m
External square drive (inch)	3/4
Length mm (L)	657 mm
b1	28 mm
b2	50 mm
Height mm (h1)	23 mm
Height mm (h2)	31,5 mm
DIN	DIN EN ISO 6789-2:2017
LF	564,5 mm
Weight with box	2657 g

## Logistics data.

Product no.	96502140
GTIN	4018754180523
Weight (g)	2122 g
Volume (packaged, dm <sup>3</sup> )	4.4114 dm <sup>3</sup>
Packing standard	1
WEEE/ElektroG	nicht ear-pflichtig
Customs tariff no.	82041100
Country of origin AWR	GERMANY
Region of origin	Nordrhein-Westfalen
Depth mm (IFS)	685
Width mm (IFS)	92
Height mm (IFS)	70
Weight (gross, kg)	2,910
Weight PAP (kg)	0,130
Weight PVC (kg)	0,000
Length (packaged, mm)	685
Width (packaged, mm)	92
Height (packaging, mm)	70

## Parts list.



81370003

Plastic box, empty

## GTIN.



**STAHLWILLE Eduard Wille GmbH**

Lindenallee 27 · 42349 Wuppertal · Germany · Phone: +49 202 4791-0

[info@stahlwille.de](mailto:info@stahlwille.de) · [www.stahlwille.com](http://www.stahlwille.com)

© STAHLWILLE Eduard Wille GmbH, Wuppertal