



Electronic workshop tester SENSOTORK®

7707-2W

Product no. **96521072**
GTIN **4018754155781**
Model **7707-2W**



Label.

Electronic workshop testing device SENSOTORK® Measuring r.2-100N·m Internal square drive 3/8"

Properties.

- for testing indicating and triggering torque screwdrivers
- compact electronic testing device consisting of:
 - 1 patented transducer
 - 1 safety lock
 - 1 display device
 - 1 stand with 1.5 metre cable for the display unit
 - 1 spiral cable
 - 1 power supply (110 V-230 with interchangeable plug adapters)
 - 4 interchangeable square drive adapters for the square drive
- large LCD display for optimum readability
- horizontal or vertical installations
- for controlled right and left measuring
- 3 operating modes: running display of the applied torque (Track), display of the torque on triggering/kink point detection (First-Peak), peak value display (Peak-Hold)
- additional control from the display of the actual tightened torque on triggering torque wrenches
- with QuickRelease security lock
- low transverse forces due to flat transducers
- automatic detection of transducers
- particularly large measurement range from about 2% to 100% of the nominal value
- 3 measuring units (N·m, ft·lb, in·lb)
- software No. 7759-4, including USB adapter and jack cable, allows the measured values to be transmitted to a PC (no additional external power source, power from the PC)
- when recalibrating the individual transducers, the test equipment remains operational on site
- complies with the specifications of guideline DKD-R 10-8
- with certificate
- delivered in a sturdy plastic box

Benefits.

Electronic workshop tester for checking and adjusting indicating and triggering torque wrenches.

Simple, quick and reliable testing of torque wrenches to ensure quality in production.

Measurement in the large torque range up to 1.100 N·m.

Simple exchange of transducers enables quick adjustment to different measuring tasks and specific testing requirements.

The interchangeable square adapters in the mounting block allow flexible use with standard square drive sizes.



Product highlights.



PRODUCT IMAGE
IN PROGRESS

Flexible mounting.

Whether mounted horizontally or vertically - the well-designed mounting points, compact design and rotatable display allow flexible positioning anywhere in the workshop.



PRODUCT IMAGE
IN PROGRESS

Customized drive solution.

Up to 4 square adapters are integrated into the mounting block of the device, within easy reach, to enable flexible use with standard square drive sizes.



PRODUCT IMAGE
IN PROGRESS

Adaptive measuring system.

Our SENSOTORK® 7707W features easily interchangeable transducers. This gives it the ability to be customized for individual measurement requirements.



PRODUCT IMAGE
IN PROGRESS

Resistance to transverse forces.

The high level of accuracy is achieved by flat transducers and a special technology for immediate data processing directly in the transducer. Thanks to an integrated measurement amplifier, the testing device is resistant to bending moments and transverse forces.

Technologies and features.



QuickRelease

The QuickRelease safety lock helps you to quickly mount and change transducers. The sensors lock into the calibration system adapter and only unlock again at the push of a button.



DIN EN ISO 6789-2

Our torque wrenches and torque screwdrivers are professionally calibrated in accordance with DIN EN ISO 6789-2 and delivered with a corresponding calibration certificate. We also calibrate angle-controlled torque wrenches in accordance with VDI 2648-2. This ensures the accuracy and traceability of our tools.

Technical drawing.

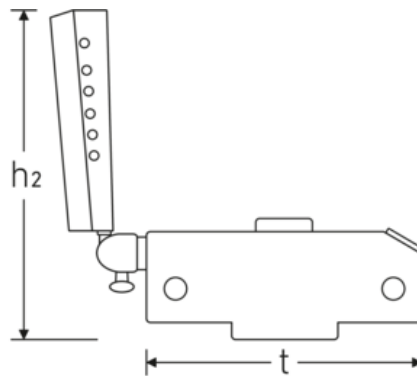
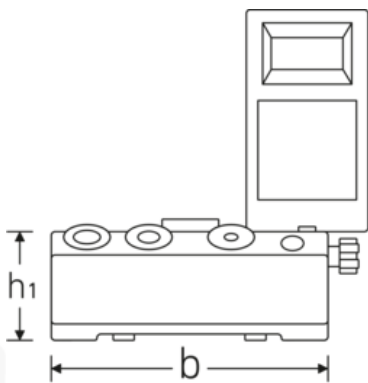

Technical attributes.

Measuring range N·m	2-100 N·m
Internal square [inch]	3/8 "
Width mm (b)	180 mm

Logistics data.

Depth mm (IFS)	430
Width mm (IFS)	340
Height mm (IFS)	170

Weight with box	10300 g	WEEE/ElektroG	Kleingeräte B2C
Height mm (h1)	79 mm	Length (packaged, mm)	430
Height mm (h2)	215 mm	Width (packaged, mm)	340
Model No.	7707-2W	Height (packaging, mm)	170
t	180 mm	Volume (packaged, dm3)	24.854 dm3
		Product no.	96521072
		Weight (gross, kg)	9,680
		Weight PAP (kg)	0,016
		Weight PVC (kg)	0,000
		GTIN	4018754155781
		Country of origin AWR	GERMANY
		Region of origin	Nordrhein-Westfalen
		Customs tariff no.	90318080
		Packing standard	1
		Weight (g)	7025 g

Parts list.



81320002
Plastic case



52110056
Mains adapter



52110052
Spiral cable



52110051
Jack cable



52100059
Transducer in case



52100058
Transducer in case



52100051
Body mount



52100050
Display device for torque display



11030010
Square drive adaptor

Variants.

Product no.	Model No. (ERP)	Description	GTIN
96521086	7707-1-3W	Electronic workshop testing device SENSOTORK® Measuring r.0.2-10N·m Internal square drive 1/4"	4018754241958
96521085	7707-1-2W	Electronic workshop testing device SENSOTORK® Measuring r.0.2-10N·m Internal square drive 1/4"	4018754241941
96521080	7707N-1W	Electronic workshop testing device SENSOTORK® Measuring r.0.4-20N·m Internal square drive 1/4"	4018754181148
96521072	7707-2W	Electronic workshop testing device SENSOTORK® Measuring r.2-100N·m Internal square drive 3/8"	4018754155781
96521083	7707-2-1W	Electronic workshop testing device SENSOTORK® Measuring r.4-200N·m Internal square drive 1/2"	4018754181162
96521084	7707-2-2W	Electronic workshop testing device SENSOTORK® Measuring r.8-400N·m Internal square drive 3/4"	4018754181179
96521082	7707N-3W	Electronic workshop testing device SENSOTORK® Measuring r.25-1100N·m Internal square drive 3/4"	4018754181155

GTIN.



STAHLWILLE Eduard Wille GmbH

Lindenallee 27 · 42349 Wuppertal · Germany · Phone: +49 202 4791-0

info@stahlwille.de · www.stahlwille.com

© STAHLWILLE Eduard Wille GmbH, Wuppertal