



Torque wrench service MANOSKOP® (N·m)

730 Quick



Product no. 50184002
GTIN 4018754292653
Model 730/2 QUICK



Label.

Torque wrench service MANOSKOP® (N·m) 730 Quick 4-20N·m 9 x 12 mm L. 179mm

Product highlights.



Rapid adjustment.

Easy and quick adjustment of the torque is carried out by an easy-to-operate clamping lever in the handle. The scale can be moved quickly and safely with an ergonomically shaped, non-slip adjustment element with thumb recess.



Adjustment does not require disassembly.

Quick adjustment from outside, no disassembly of the torque wrench required, with 2 adjustment points for the maximum & minimum values.

Technologies and features.



QuickRelease

The QuickRelease safety lock prevents unintentional loss of insert tools. These click securely into place, and are only released again at the push of a button for a quick tool change. In transducers: The QuickRelease safety lock helps you to quickly mount and change transducers. The transducers lock into the calibration system and only unlock again at the push of the buttons.



Low-wear bending beam system

Our torque wrench is equipped with a low-wear release system with a bending beam. Unlike conventional torque wrenches with coiled springs, the bending beam is not subjected to any load until the tool is in operation, which means that the spring does not need to be reset to '0' after use.



2-component handle

Our 2-component handle is non-slip and ergonomically designed. It is resistant to the most common oils, greases, fuels, brake fluids, and Skydrol. The arrow markings on the handle indicate the direction of operation.



DIN EN ISO 6789-2

Our torque wrenches and torque screwdrivers are professionally calibrated in accordance with DIN EN ISO 6789-2 and delivered with a corresponding calibration certificate. We also calibrate angle-controlled torque wrenches in accordance with VDI 2648-2. This ensures the accuracy and traceability of our tools.

Technical drawing.

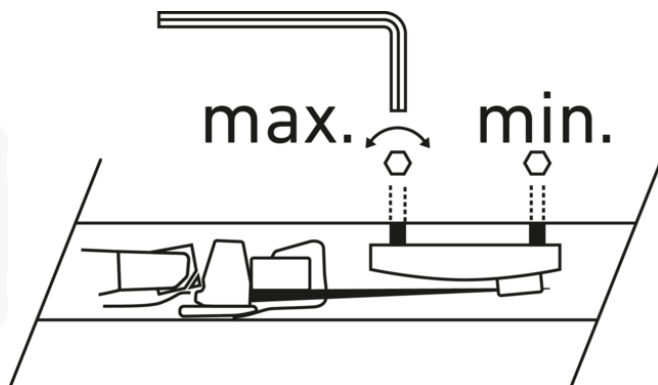
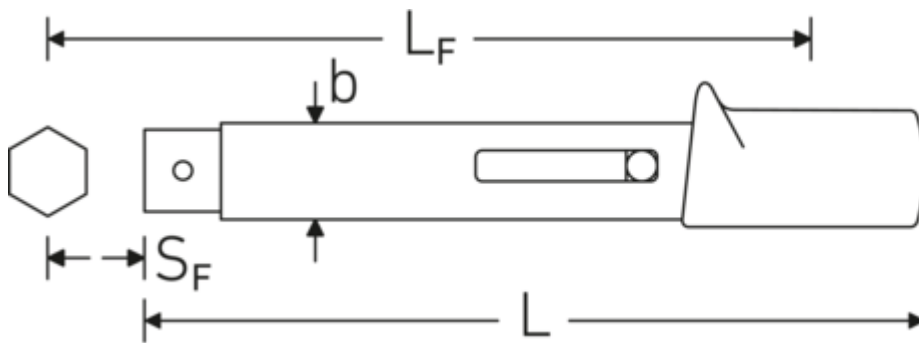

Technical attributes.

Scale division N·m	0,5 N·m
Measuring range N·m	4-20 N·m
Width mm (b)	27,5 mm
Size	2
Tool holder size [internal square]	9 x 12 mm
Height mm (h)	23,6 mm
Length mm (L)	179 mm
LF	157,2 mm
SF	17,5 mm

Logistics data.

Depth mm (IFS)	182
Width mm (IFS)	45
Height mm (IFS)	30
WEEE/ElektroG	nicht ear-pflichtig
Length (packaged, mm)	250
Width (packaged, mm)	55
Height (packaging, mm)	55
Volume (packaged, dm ³)	0.75625 dm ³
Product no.	50184002
Weight (gross, kg)	0,400
Weight PAP (kg)	0,000
Weight PVC (kg)	0,066
GTIN	4018754292653
Country of origin AWR	GERMANY
Region of origin	Nordrhein-Westfalen
Customs tariff no.	82041100
Packing standard	1
Weight (g)	315 g

Variants.

Product no.	Model No. (ERP)	Description	GTIN
91381054	730/2-1 BW QUICK	Torque wrench service MANOSKOP® (N·m) 730 Quick 2-10N·m 9 x 12 mm L. 179mm	4018754320325
50184001	730/2-1 QUICK	Torque wrench service MANOSKOP® (N·m) 730 Quick 2-10N·m 9 x 12 mm L. 179mm	4018754359035
50184002	730/2 QUICK	Torque wrench service MANOSKOP® (N·m) 730 Quick 4-20N·m 9 x 12 mm L. 179mm	4018754292653
50184004	730/4 QUICK	Torque wrench service MANOSKOP® (N·m) 730 Quick 8-40N·m 9 x 12 mm L. 223mm	4018754292660

GTIN.



STAHLWILLE Eduard Wille GmbH

Lindenallee 27 · 42349 Wuppertal · Germany · Phone: +49 202 4791-0

info@stahlwille.de · www.stahlwille.com

© STAHLWILLE Eduard Wille GmbH, Wuppertal