



Mobile workbench

WB 625

Product no. **85010625**
GTIN **4018754334018**
Model **WB 625**



Label.

Mobile workbench WB 625 7 Drawer anthracite, RAL 7016; black, RAL 9005
L.500mm x W.1150mm x H.1045mm

Properties.

- **three-stage safety concept:**
 1. central locking with a lateral cylinder lock and hinged key
 2. individual locks prevent inadvertent opening during transit
 3. tilt protection - makes it impossible to pull out several drawers at the same time
- 7 easily removable drawers, black, full-extension runners with bearing cage guide
- large work surface with multiplex beechwood worktop (with FSC certification), 1150 x 500 x 30 mm
- oil and acid-resistant wheels (Ø 125 mm) with thread guards to protect the bearings from dirt and threads, with 2 locking brakes
- paper roll holder
- RAL 7016 body, RAL 9005 drawers and cabinet compartment, in durable industrial powder coating
- can be fitted with STAHLWILLE standard and TCS inserts, 1 x 3/3 + 1 x 2/3 TCS insert per drawer
- drawer dimensions: 880 x 350 mm
- drawer internal heights: 4 x 75 ;2 x 110; 1 x 150 mm
- two-sided perforated panel for hooks (No. 8031-8041)

Benefits.

Birchwood multiplex worktop with a working height of 104 cm, FSC-certified.

Three-stage safety concept with single lock and foldable key.

Includes an individually adjustable paper roll holder for paper rolls up to 30 cm wide and a perforated panel on both sides.

7 extra wide drawers with fully-extendable runners.

Outstanding durability thanks to the cleverly designed and sturdy construction.



Product highlights.



Ergonomic height.

The working height of 104 cm and the particularly large, FSC-certified worktop makes work more comfortable.



Maximum storage space.

Everything in XXL. 7 removable drawers with full extension runners and a width of 880 mm offer plenty of storage space. For example, a 3/3 (XL) TCS inlay fits in a drawer together with a 2/3 (L) TCS inlay.



Secure down to the last detail.

The central lock with countersunk, side-mounted cylinder lock, together with the foldable key, protects against injury and damage. The individual locking mechanism prevents unintentional opening during transit - the anti-tilt protection makes it impossible to pull out multiple drawers simultaneously.



Reliable construction.

High-quality materials ensure the durability one expects from STAHLWILLE, such as the robust body and drawers with industrial powder coating. The oil and acid-resistant smooth-running wheels (Ø 125 mm) are equipped with guards to protect the bearings from dirt and fibres, and with 2 locking brakes.



Perfectly equipped.

Our workbench is of course also available directly with matching tool sets. However, we are also happy to put together sets according to customer requirements for individual requirements. Just talk to us.

Technologies and features.



Modular Inlay System

This flexible solution for tool storage makes it possible to customize your tool trolleys and workbenches with 1/6, 1/3, 2/3 or 3/3 foam inlays.

Technical drawing.

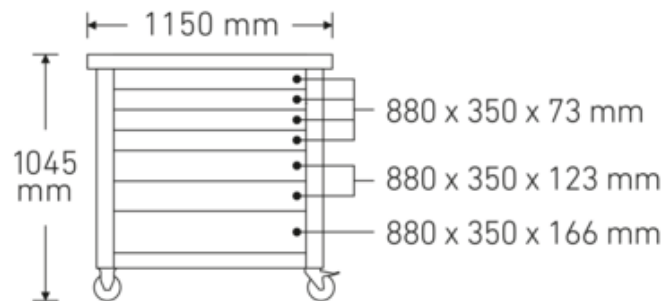
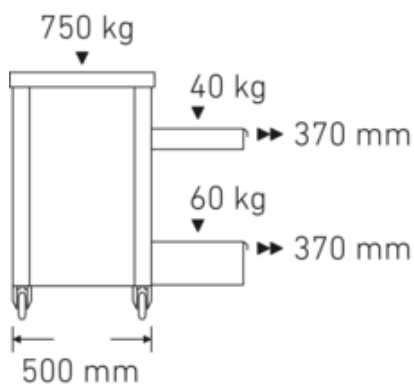

Technical attributes.

Number of drawers	7
Width mm (b)	1150 mm
Colour	anthracite, RAL 7016; black, RAL 9005
Height mm (h)	1045 mm
Length mm (L)	500 mm
Internal drawer dimensions mm	880 x 351 x 73 mm (4x) 880 x 351 x 123 mm (2x) 880 x 351 x 166 mm (1x)
Drawer load capacity	40 kg 40 kg 60 kg
Load capacity	750 kg

Logistics data.

Depth mm (IFS)	1150
Width mm (IFS)	500
Height mm (IFS)	890
WEEE/ElektroG	nicht ear-pflichtig
Length (packaged, mm)	1200
Width (packaged, mm)	555
Height (packaging, mm)	948
Volume (packaged, dm ³)	631.368 dm ³
Product no.	85010625
Weight (gross, kg)	106,500
Weight PAP (kg)	7,000
Weight PVC (kg)	0,180
GTIN	4018754334018
Region of origin	Ausländischer Ursprung
Customs tariff no.	94032080
Packing standard	1
Weight (g)	97000 g

Variants.

Product no.	Model No. (ERP)	Description	GTIN
85010625	WB 625	Mobile workbench WB 625 7 Drawer anthracite, RAL 7016; black, RAL 9005 L.500mm x W.1150mm x H.1045mm	4018754334018

GTIN.



Accessories (for).



80310090
Single hook



90432727
Spray can holder



80320060
Twin hook



80340040
Twin hook



89010040
Cable holder



80340050
Twin hook



83812070
Empty tray for small components



80350017
Square lug



81484001
Drawer divider



80350020
Square lug



80360012
Spring clip



81484002
Drawer divider



80360018
Spring clip



81485006
Spring clip



80360024
Spring clip



81485012
Spring clip



80380030
Container



80410235
Holding device for
wrenches



80310030
Single hook



80310060
Single hook



89010041
Laptop holder



80320030
Twin hook

Spare part(s), spare part(s) for.



90432731
Multiplex beechwood
worktop



81490001
Wheel set



89480003
Set of wheels



81490005
Wheel set

Images.





STAHLWILLE Eduard Wille GmbH

Lindenallee 27 · 42349 Wuppertal · Germany · Phone: +49 202 4791-0

info@stahlwille.de · www.stahlwille.com

© STAHLWILLE Eduard Wille GmbH, Wuppertal