

Mobile workbench WB 621

WB 621



Product no.	85010621
GTIN	4018754336241
Model	WB 621

Label. Mobile workbench WB 621 7 Drawers anthracite, RAL 7016; black, RAL 9005
L.500mm x W.1150mm x H.1045mm

- Features.**
- **three-stage safety concept:**
 1. central locking with a lateral cylinder lock and hinged key
 2. individual locks prevent inadvertent opening while in transit
 3. tilt protection – makes it impossible to pull out several drawers at the same time
 - 7 easily removable drawers with full extension and ball bearing cage guide
 - 2 drawers in generous XXL format, 880 mm
 - separate lockable cabinet with magnetic bracket and adjustable shelves (70 mm grid)
 - drawers and cabinet section close at the same time
 - large work surface with multiplex beechwood worktop (with FSC certification), 1150 x 500 x 30 mm
 - cabling through two rubberised grommets
 - removable cable duct on the back side
 - oil and acid-resistant wheels (125 mm diameter) with thread guards to protect the bearings from dirt and threads, with two locking brakes
 - paper roll holder
 - body RAL 7016, drawers RAL 9005 in durable industrial powder coating
 - can be equipped with STAHLWILLE standard and TCS inserts, 1 x 3/3 (XL) + 1 x 2/3 (L) TCS inserts for drawers 1 and 2; 1 x 3/3 (XL) for drawer 3–7
 - stainless steel decorative trim
 - two-sided perforated panel for hooks (no. 8031-8041)
 - optional: E-kit with one 3-way socket, two USB ports, cable holder and magnetic mounting bracket

Advantages.

Three-stage safety concept: 1. Central locking by side cylinder lock with folding key 2. Individual locks prevent inadvertent opening while in transit 3. Tilt protection – it is not possible to pull out several drawers at the same time.

With 7 full-extension drawers, 2 of them in XXL format, and lockable cabinet section.

Three-stage security concept with single lock and foldable key.

With cable outlets and a cable duct for an organized and safe working environment.

Can be extended with an e-kit with triple socket, cable and magnetic holder and USB ports.



Product highlights.



Perfectly equipped.

Of course, our workbench is also available with matching tool sets. However, in case of individual requirements, we are also happy to assemble bespoke sets for our customers. Just get in touch.



Ergonomic height.

The working height of 104 cm and the particularly large, FSC-certified worktop makes work more comfortable.



Well thought out, sturdy design.

High-quality materials ensure the durability that is typical of STAHLWILLE, such as the sturdy housing and drawers with their industrial powder coating. The oil- and acid-resistant lightweight wheels (Ø 125 mm) are equipped with guards to protect the bearings from dirt and fibres, with two locking brakes.



Three-stage safety concept.

The central lock with countersunk, side-mounted cylinder lock, together with the foldable key, protects against injury and damage. The individual locking mechanism prevents unintentional opening during transit – the anti-tilt protection makes it impossible to pull out multiple drawers simultaneously.

Technical Drawing.

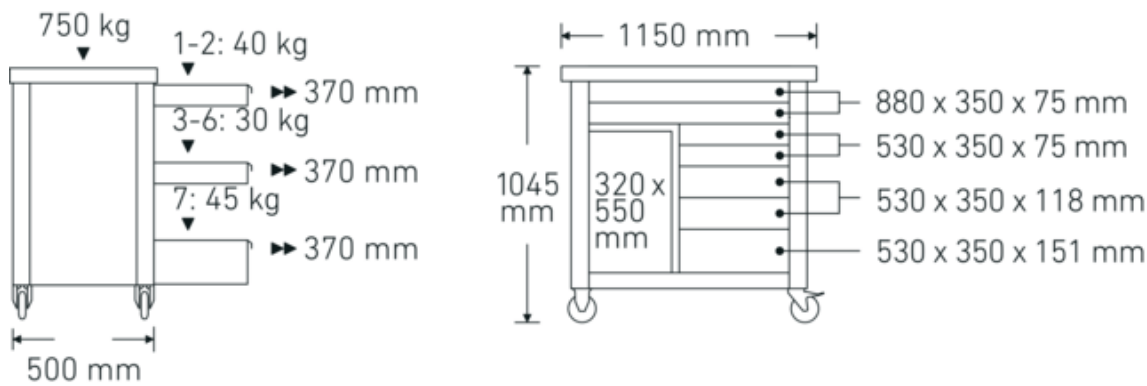

Technical Attributes.

Number of drawers	7
Width mm (b)	1150 mm
Colour	anthracite, RAL 7016; black, RAL 9005
Height mm (h)	1045 mm
Length mm (L)	500 mm
No.	WB 621
Internal drawer dimensions mm	880 x 350 x 75 (2x) 530 x 350 x 75 (2x) 530 x 350 x 118 (2x) 530 x 350 x 151 (1x)
Drawer load capacity	40 kg 30 kg 30 kg 45 kg
Load capacity	750 kg

Logistics data.

Depth mm (IFS)	1150
Width mm (IFS)	500
Height mm (IFS)	890
Length (packed, mm)	1160
Width (packed, mm)	550
Height (packed, mm)	930
Volume (packed, dm ³)	593.34 dm ³
Product no.	85010621
Weight (gross, kg)	115,000
Weight PAP (kg)	7,500
Weight PVC (kg)	0,000
GTIN	4018754336241
Country of origin	CHINA
Region of origin	Ausländischer Ursprung
WEEE/ElektroG	nicht ear-pflichtig
Customs tariff no.	94032080
Packing standard	1

Variants.

Product no.	Art. no. (ERP)	Description	GTIN
85010621	WB 621	Mobile workbench WB 621 7 Drawers anthracite, RAL 7016; black, RAL 9005 L.500mm x W.1150mm x H.1045mm	4018754336241

GTIN-Code.



Accessories.



90432727
Spray can holders

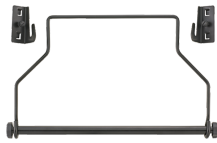

81483004
Paper roll holder



89010040
Cable holder



83812070
Empty tray for small
components



81484001
Drawer dividers

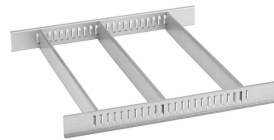

81484002
Drawer dividers



89010003
Anti-slip mat GRIPMAT



90432728
Electronic set

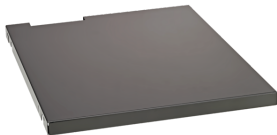

90432736
Shelf



89010041
Laptop holder

Spare parts/spare part for.



90432731
Multiplex beechwood
worktop



81490001
Set of wheels

Images.

