



## Mobile workbench

### WB 625

Product no. **85010625**  
GTIN **4018754334018**  
Model **WB 625**

**Label.** Mobile workbench WB 625 7 Drawers anthracite, RAL 7016; black, RAL 9005  
L.500mm x B.1150mm x H.1045mm

**Features.**

**three-stage safety concept:**

1. central locking with a lateral cylinder lock and hinged key
2. individual locks prevent inadvertent opening while in transit
3. tilt protection – it is not possible to pull out several drawers at the same time

- 7 easily removable drawers with full extension and ball bearing cage guide
- Large work surface with multiplex beechwood worktop (with FSC certification), 1150 x 500 x 30 mm
- oil- and acid-resistant wheels (125 mm diameter) with thread guards to protect the bearings from dirt and threads, with two locking brakes
- paper roll holder
- body RAL 7016, drawers RAL 9005 in sturdy industrial powder coating
- can be fitted with STAHLWILLE standard and TCS inserts, 1 x 3/3 + 1 x 2/3 TCS insert per drawer
- drawer dimensions 880 x 350mm, inner drawer heights: 4 x 72 mm, 2 x 110 mm, and 1 x 150 mm
- two-sided perforated panel for hooks (No. 8031-8041)

## Advantages.

Birchwood multiplex worktop with a working height of 104 cm, FSC-certified.

Three-stage safety concept with single lock and foldable key.

Includes an individually adjustable paper roll holder for paper rolls up to 30 cm wide and a perforated panel on both sides.

Seven extra wide drawers with fully-extendable runners.

Outstanding durability thanks to the cleverly designed and sturdy construction.



## Product highlights.



### Ergonomic height.

The working height of 104 cm and the particularly large, FSC-certified worktop makes work more comfortable.



### Maximum storage space.

Everything in XXL. Seven removable drawers with full extension runners and a width of 880 mm offer plenty of storage space. For example, a 3/3 (XL) TCS insert fits in a drawer together with a 2/3 (L) TCS insert.



### Three-stage safety concept.

The central lock with countersunk, side-mounted cylinder lock, together with the foldable key, protects against injury and damage. The individual locking mechanism prevents unintentional opening during transit - the anti-tilt protection makes it impossible to pull out multiple drawers simultaneously.



### Well thought out, sturdy design.

High-quality materials ensure the durability one expects from STAHLWILLE, such as the robust body and drawers with industrial powder coating. The oil and acid-resistant smooth-running wheels (Ø 125 mm) are equipped with guards to protect the bearings from dirt and fibres, and with two locking brakes.



### Perfectly equipped.

Of course, our workbench is also available with matching tool sets. However, in case of individual requirements, we are also happy to assemble bespoke sets for our customers. Just get in touch.

## Technologies and features.

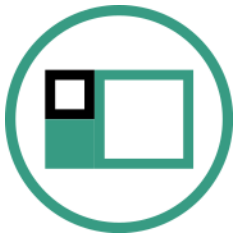

### Modular Inlay System

This flexible solution for tool storage makes it possible to customise your tool trolley or tool box with 1/6, 1/3, 2/3 or 3/3 foam inserts.

## Technical Drawing.

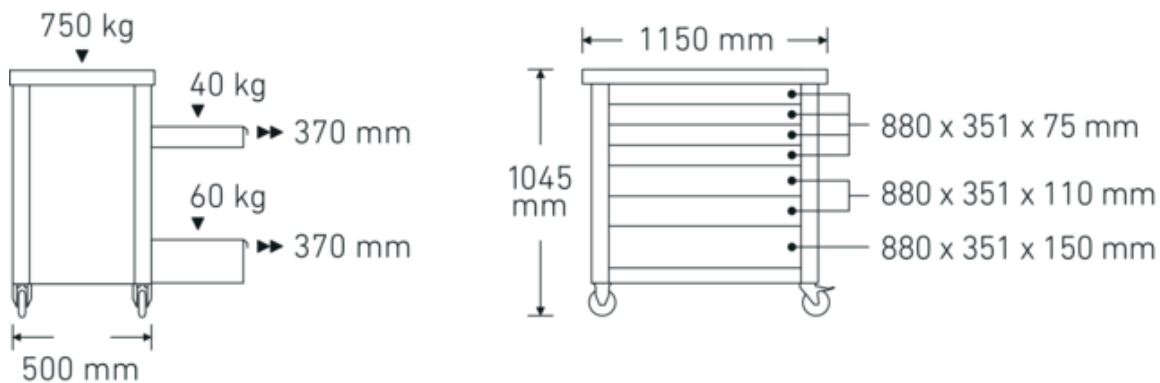

## Technical Attributes.

Number of drawers	7
Width mm (b)	1,150 mm
Colour	anthracite, RAL 7016; black, RAL 9005
Height mm (h)	1045 mm
Length mm (L)	500 mm
Model no.	WB 625
Internal drawer dimensions mm	880 x 351 x 75 mm (4x) 880 x 351 x 110 mm (2x) 880 x 351 x 150 mm (1x)
Drawer load capacity	40 kg 40 kg 60 kg
Load capacity	750 kg

## Logistics data.

Depth mm (IFS)	1150
Width mm (IFS)	500
Height mm (IFS)	890
Length (packed, mm)	1200
Width (packed, mm)	555
Height (packed, mm)	948
Volume (packed, dm <sup>3</sup> )	631.368 dm <sup>3</sup>
Product no.	85010625
Weight (gross, kg)	106,500
Weight PAP (kg)	7,000
Weight PVC (kg)	0,180
GTIN	4018754334018
Country of origin AWR	CHINA
Region of origin	Ausländischer Ursprung
WEEE/ElektroG	nicht ear-pflichtig
Customs tariff no.	94032080
Packing standard	1

## Variants.

Product no.	Model no. (ERP)	Description	GTIN
85010625	WB 625	Mobile workbench WB 625 7 Drawers anthracite, RAL 7016; black, RAL 9005 L.500mm x B.1150mm x H.1045mm	4018754334018

## GTIN-Code.



## Accessories.



90432727  
Spray-can holder



89010040  
Cable holder



83812070  
Empty tray for small components



81484001  
Drawer separator

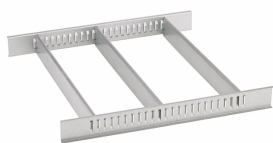

81484002  
Drawer divider



89010041  
Laptop holder

## Spare parts/spare part for.



90432731  
Multiplex beechwood  
worktop



81490001  
Set of wheels

## Images.

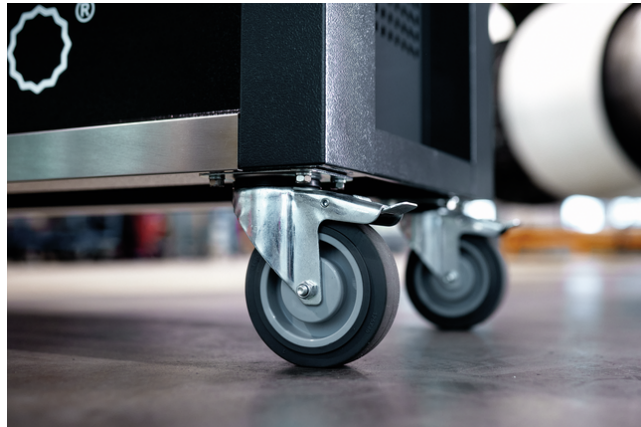



**STAHLWILLE Eduard Wille GmbH & Co. KG**

Lindenallee 27 · 42349 Wuppertal · Germany · Phone: +49 202 4791-0 · Fax: +49 202 4791-200  
info@stahlwille.de · www.stahlwille.com · Copyright by STAHLWILLE Eduard Wille GmbH & Co. KG, Wuppertal  
Copyright by STAHLWILLE Eduard Wille GmbH & Co. KG, Wuppertal