



Tool trolley 95 PRO

95/8 PRO

Product no. **81200167**
GTIN **4018754334704**
Model **95/8 B PRO**

Label. Tool trolley 95/8 PRO 8 Drawers 496 x 827 x 1020 mm blue, RAL 270 30 35

Features.

- **three-stage safety concept:**
 1. central locking with a lateral cylinder lock and hinged key
 2. individual locks prevent inadvertent opening while in transit
 3. topple proof – it is not possible to pull out several drawers at the same time.
- stainless steel handle with reinforced frame connection
- all-round frame protection with shock absorption
- tightly welded, resilient work surface, storage area, and end panel made of stainless steel
- oil and acid-resistant ball-bearing smooth-running wheels (125 mm diameter) with thread guards to protect the bearings from dirt and threads, with two locking brakes
- paper roller and spray can holder included
- 8 easy-to-remove drawers (black RAL 9005) with full-extension runners and bearing cage guide
- hole pattern on both sides for hooks No. 8031-8041, e.g., for larger tools
- can be fitted with STAHLWILLE standard and TCS inserts

Advantages.

Three-stage safety concept: 1. Central locking by side cylinder lock with folding key 2. Individual locks prevent inadvertent opening while in transit 3. Tilt protection – it is not possible to pull out several drawers at the same time



Product highlights.



Durable wheels.

Oil and acid resistant smooth-running wheels (Ø 125 mm) with carpet protection to protect the bearings from dirt and fibres; with two locking brakes.



Optimally organised.

All drawers can be extended up to 100%. Combining the use of STAHLWILLE standard and TCS inserts, or the variable drawer dividers, ensures a clear overview and convenient access to tools.

Technologies and features.



Tool Control System

The intelligent modular insert system protects and organises the tools in tool boxes, workshop trolleys and workshop benches. Two-colour foam inlays make checking the completeness of the tools quick and easy.

Technical Drawing.

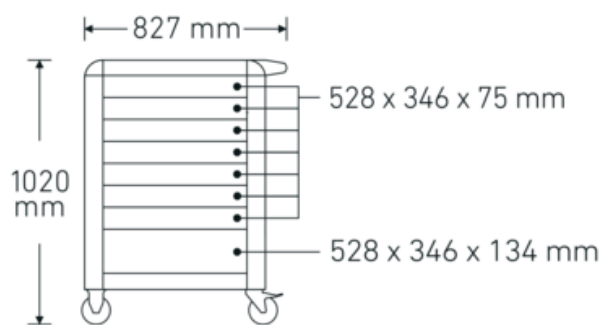
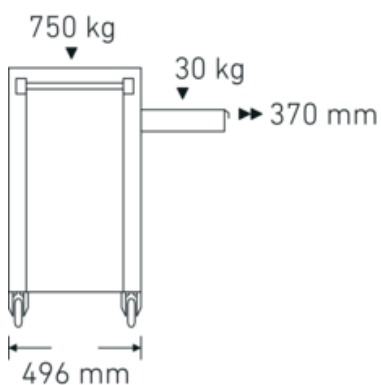

Technical Attributes.

Number of drawers	8
Width mm (b)	827 mm
Colour	blue, RAL 270 30 35
Colour abbreviation	RAL 270 30 35; RAL 9005

Logistics data.

Depth mm (IFS)	720
Width mm (IFS)	496
Height mm (IFS)	863
Length (packed, mm)	836
Width (packed, mm)	587

Height mm (h)	1020 mm	Height (packed, mm)	940
Length mm (L)	496 mm	Volume (packed, dm3)	461.28808 dm3
Model no.	95/8 B PRO	Product no.	81200167
Internal drawer dimensions mm	346 x 528 x 75 mm (7x) 346 x 528 x 134 mm (1x)	Weight (gross, kg)	79,000
Drawer load capacity	30 kg 45 kg	Weight PAP (kg)	7,500
Load capacity	750 kg	Weight PVC (kg)	0,000
		GTIN	4018754334704
		Country of origin AWR	CHINA
		Region of origin	Ausländischer Ursprung
		WEEE/ElektroG	nicht ear-pflichtig
		Customs tariff no.	94032080
		Packing standard	1
		Weight	71500 g

Variants.

Product no.	Model no. (ERP)	Description	GTIN
81200166	95/8 A PRO	Tool trolley 95/8 PRO 8 Drawers 496 x 827 x 1020 mm anthracite, RAL 7016; black, RAL 9008	4018754334698
81200167	95/8 B PRO	Tool trolley 95/8 PRO 8 Drawers 496 x 827 x 1020 mm blue, RAL 270 30 35	4018754334704
81200168	95/8 R PRO	Tool trolley 95/8 PRO 8 Drawers 496 x 827 x 1020 mm red, RAL 3020; black RAL 9005	4018754334711

GTIN-Code.



Accessories.



90432802
Protective cover



90432727
Spray-can holder

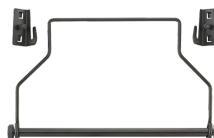

81483004
Paper roll holder



89010040
Cable holder



83812070
Empty tray for small
components

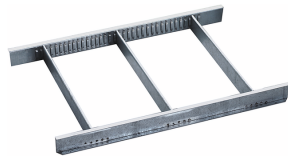

81484001
Drawer separator



81484002
Drawer divider



89011053
Waste bin



89010042
Laptop holder adaptor

Spare parts/spare part for.

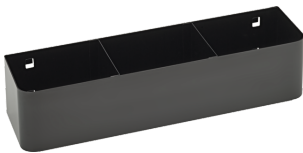

90432719
Spray-can holder



81490001
Set of wheels

Images.



STAHLWILLE Eduard Wille GmbH & Co. KG

Lindenallee 27 · 42349 Wuppertal · Germany · Phone: +49 202 4791-0 · Fax: +49 202 4791-200
info@stahlwille.de · www.stahlwille.com · Copyright by STAHLWILLE Eduard Wille GmbH & Co. KG, Wuppertal
Copyright by STAHLWILLE Eduard Wille GmbH & Co. KG, Wuppertal